

Model 870A

Ultra-Low Phase Noise RF Signal Generator

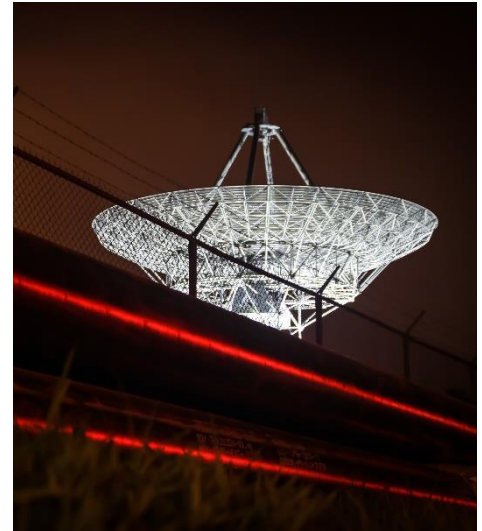

Features

- Outstanding phase noise, harmonic and spurious performance
- Low power consumption and low power dissipation
- Less than 20 ppb/yr. aging
- Fast switching of $<10 \mu\text{s}$ (option FS)

Applications

- R&D low noise signal source
- Production automated testing
- Telecommunication service and maintenance
- Radar signal simulation
- Aerospace & Defense
- Automotive Radar for self-driving technology



Model 870A

9 kHz to 12.75, 20, 40 and 54 GHz

CONTENTS

DEFINITIONS	4
INTRODUCTION	4
SPECIFICATIONS	5
Signal Specifications	5
Frequency Reference	5
Absolute Phase Noise.....	6
Absolute SSB Phase noise dBc/Hz.....	6
Absolute SSB Phase noise with LN/LN+ option dBc/Hz.....	6
Spectral Purity	7
Phase Coherence.....	8
Level Performance	8
Power Level Uncertainty	9
Relative Power Error (0.1 dB step)	10
Modulation Capabilities	10
Sweeping Capability	12
Trigger (TRIG IN).....	12
Multi-Purpose Output (FUNC OUT)	13
CONNECTORS	14
Front panel (19" 2U)	14
Rear Panel (19" 2U).....	14
High Isolation Casing 19" U (rack mount kit included)	15
Front panel (Bench top)	15
.....	15
Rear panel (Bench top)	15
MECHANICAL SPECIFICATIONS	16
Desktop enclosure: Dimensions & Weight.....	16
19" 2U: Dimensions & Weight	16
ORDERING INFORMATION	17
GENERAL CHARACTERISTICS	18
DOCUMENT HISTORY	19
NOTES	20

DEFINITIONS

The specifications in the following pages describe the warranted performance of the instrument for 23 ± 5 °C after a 30-minute warm-up period.

Typical: Expected mean values, not warranted performance

Min and max: Parameter range that is guaranteed by product design, and/or production tested. Warranted performance specifications include guard-bands to account for the expected statistical performance distribution, measurement uncertainties, and changes in performance due to environmental conditions.

INTRODUCTION

The Model 870A is a series of phase-coherent, single, or multi-channel, ultra-fast switching, and ultra-low phase noise signal generators with a frequency range up to 20, 40, and 54 GHz. It is ideally suited for a wide range of applications, where good signal quality, accurate and wide output power ranges, and very stable phase coherence among all channels are required. Excellent phase noise is combined with good spurious, harmonic rejection and optionally leading-edge switching speed of 15 μ s.

A high-stability OCXO reference provides excellent frequency accuracy and stability. The generator accepts a wide range of external references including the commonly used 10 and 100 MHz for higher phase synchronization, and a flexible reference choice in the range of 1-250 MHz for those applications with customer- or system-specific reference frequencies. Moreover, the Model 870A features a pair of Berkeley Nucleonics proprietary 3 GHz high-frequency clock ports (one input and one output) that enables excellent phase synchronization among the outputs of multiple Model 870A instruments.

The Model 870A comes in a standard desktop enclosure (single channel) or in a 19-inch 2U (1 up to 4 channels) rack-mountable module form. It can be intuitively controlled by PC based GUI software or custom software / script. Moreover, the instrument offers various communication interfaces like USB, LAN or GPIB. Each interface allows for easy and fast communication using SCPI 1999 command set. Remote control of the instrument can be quickly achieved from any host system. A customer supplied application programming interface (API) or programming examples for MATLAB, LabVIEW, C++ and other commercially available tools make the control implementation very straightforward.

SPECIFICATIONS

Signal Specifications

PARAMETER	MIN	TYPICAL	MAX	NOTE
Channels	1		4	
Frequency Ranges				
870A-12	10 MHz		12.75 GHz	
870A-20	10 MHz		20 GHz	
870A-40	10 MHz		40 GHz	
870A-50	10 MHz 9 kHz		54 GHz	Option 9K
Resolution		<0.001 Hz		
Phase adjustment range	0 deg		360 deg	Individually adjustable per channel
Phase resolution		0.1 deg		
Deterministic Relative Phase between channels (phase memory)				Option PHS
Switching Speed				After SCPI command received
CW Mode		1.5 ms		
Sweep / List Mode		500 μ s 5 μ s	15 μ s	Option FS
Thermal Drift		0.015 dB/ $^{\circ}$ C		

Frequency Reference

PARAMETER	MIN	TYPICAL	MAX	NOTE
Internal Reference Frequency		100 MHz 10 MHz		Option LN/LN+
Temperature stability 0 to 50 $^{\circ}$ C			\pm 100 ppb \pm 20 ppb	Option LN/LN+
Aging 1 st year			1000 ppb 30 ppb 20 ppb	Option LN Option LN+
Aging per day			5 ppb 0.5 ppb < 0.5 ppb	after 30 days operations Option LN Option LN+
Warm-up time		5 min		
Output of internal reference		10 MHz 100 MHz		REF OUT port, selectable
Output of High Frequency Clock		6 GHz		CLK OUT port High phase synchronous mode
Output power	-3 dBm 6 dBm		+3 dBm +12 dBm	10 MHz, 6 GHz 100 MHz
Output impedance		50 Ohms		
Bypass Internal Reference Input		100 MHz		*Options LN/LN+ are disabled
Phase lock to External Reference	1 MHz	10 MHz Integer MHz	250 MHz	REF IN port Option VREF *Options LN/LN+ are disabled
High Frequency Clock Input (Bypass internal reference)		6 GHz		CLK IN port high phase synchronous mode
Reference input level				
10 MHz or 1-250 MHz or 5 GHz	-5 dBm	0 dBm	+10 dBm	
100	+5 dBm		+13 dBm	
Lock Range				
10 MHz or 1-250 MHz			\pm 1.5 ppm	

Bypass 100 MHz			100 ppm	
Reference Input Impedance		50 Ohms		

Absolute Phase Noise

Absolute SSB Phase noise dBc/Hz.

Specified values in plain text, typical values in brackets. CW, level = 10 dBm or maximum available output power, whichever is lower

OFFSET	10 Hz	100 Hz	1 kHz	20 kHz	100 kHz	1 MHz	10 MHz
FREQUENCY							
100 MHz	-100 (-105)	-130 (-135)	-144 (-149)	-150 (-155)	-156 (-161)	-156 (-161)	-156 (-161)
1 GHz	-80 (-85)	-110 (-115)	-132 (-137)	-145 (-150)	-148 (-153)	-148 (-153)	-155 (-160)
2 GHz	-74 (-79)	-104 (-109)	-126 (-131)	-139 (-141)	-142 (-147)	-142 (-147)	-149 (-154)
3 GHz	-70 (-75)	-100 (-105)	-122 (-127)	-135 (-140)	-138 (-143)	-138 (-143)	-145 (-150)
6 GHz	-64 (-69)	-94 (-99)	-116 (-121)	-129 (-134)	-132 (-137)	-132 (-137)	-139 (-144)
10 GHz	-60 (-65)	-90 (-95)	-117 (-122)	-126 (-131)	-128 (-133)	-126 (-131)	-135 (-140)
20 GHz	-54 (-59)	-84 (-89)	-111 (-116)	-120 (-125)	-122 (-127)	-120 (-125)	-129 (-134)
40 GHz	-48 (-53)	-78 (-83)	-115 (-110)	-114 (-119)	-116 (-121)	-114 (-119)	-123 (-128)
54 GHz	-45 (-50)	-75 (-80)	-100 (-105)	-110 (-115)	-112 (-117)	-112 (-117)	-120 (-125)

Absolute SSB Phase noise with LN/LN+ option dBc/Hz

Specified values in plain text, typical values in brackets. CW, level = +10 dBm or maximum available output power, whichever is lower

OFFSET	10 Hz	100 Hz	1 kHz	20 kHz	100 kHz	1 MHz	10 MHz
FREQUENCY							
100 MHz	-116 (-121)	-132 (-137)	-144 (-149)	-150 (-155)	-156 (-161)	-156 (-161)	-156 (-161)
1 GHz	-100 (-105)	-112 (-117)	-132 (-137)	-145 (-150)	-148 (-153)	-148 (-153)	-155 (-160)
2 GHz	-94 (-99)	-106 (-111)	-126 (-131)	-139 (-141)	-142 (-147)	-142 (-147)	-149 (-154)
3 GHz	-90 (-95)	-102 (-107)	-122 (-127)	-135 (-140)	-138 (-143)	-138 (-143)	-145 (-150)
4 GHz	-88 (-93)	-100 (-105)	-120 (-125)	-133 (-135)	-136 (-141)	-136 (-141)	-143 (-148)
6 GHz	-84 (-89)	-96 (-101)	-116 (-121)	-129 (-134)	-132 (-137)	-132 (-137)	-139 (-144)
10 GHz	-80 (-85)	-91 (-96)	-117 (-122)	-126 (-131)	-128 (-133)	-126 (-131)	-135 (-140)
20 GHz	-74 (-79)	-85 (-90)	-111 (-116)	-120 (-125)	-122 (-127)	-120 (-125)	-129 (-134)
40 GHz	-68 (-73)	-79 (-84)	-115 (-110)	-114 (-119)	-116 (-121)	-114 (-119)	-123 (-128)
54 GHz	-63 (-68)	-77 (-82)	-100 (-105)	-110 (-115)	-112 (-117)	-112 (-117)	-120 (-125)

Figure 1: Phase Noise at different frequencies, power +10 dBm, Option LN

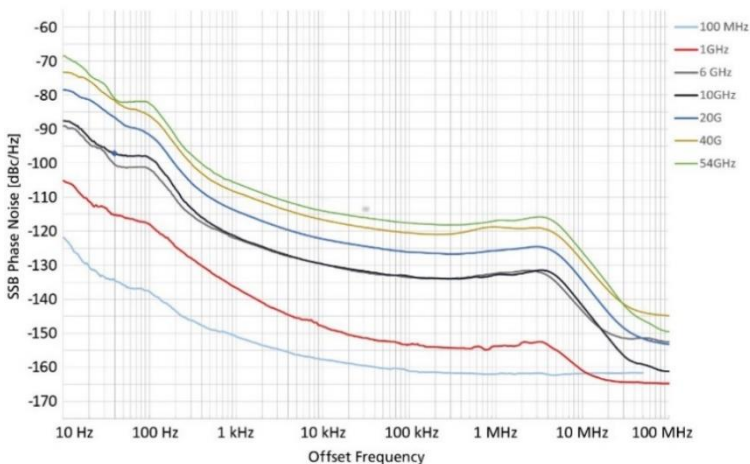
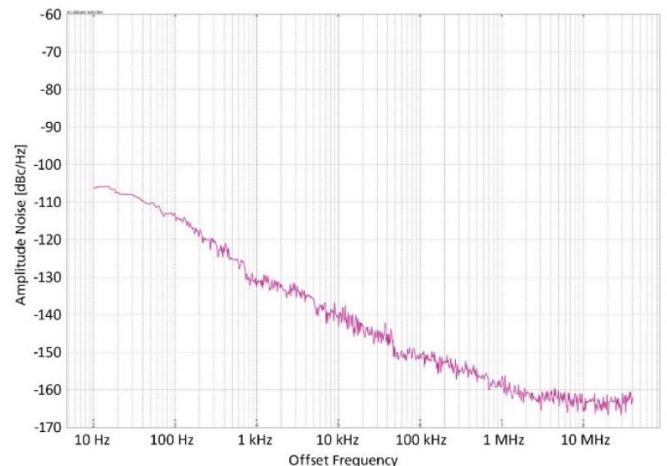

Figure 2: Amplitude Noise at 10 GHz, power +10 dBm



PARAMETER	MIN	TYPICAL	MAX	NOTE
Harmonics				At +5 dBm output power
9 kHz to 150 MHz		-30 dBc		
150 MHz to 2 GHz		-35 dBc	-30 dBc	
2 GHz to 6 GHz		-50 dBc	-45 dBc	
6 GHz to 22 GHz		-55 dBc	-50 dBc	
22 GHz to 30 GHz		-25 dBc	-20 dBc	
30 GHz to 54 GHz		-55 dBc	-50 dBc	
Sub-Harmonics				
9 kHz to 100 MHz		-80 dBc		
100 MHz to 11.3 GHz		-70 dBc	-60 dBc	
11.3 GHz to 54 GHz		-70 dBc	-55 dBc	
Non-Harmonic Spurious				10 kHz to 0.5 GHz offset from carrier
< 1.2 GHz		-95 dBc	-85 dBc	
1.2 to 2.5 GHz		-90 dBc	-86 dBc	
2.5 to 6 GHz		-85 dBc	-80 dBc	
6 to 12 GHz		-80 dBc	-74 dBc	
12 to 20 GHz		-75 dBc	-68 dBc	
20 to 40 GHz		-70 dBc	-65 dBc	
40 to 54 GHz		-67 dBc	-62 dBc	

Figure 3: Harmonics at +10 dBm

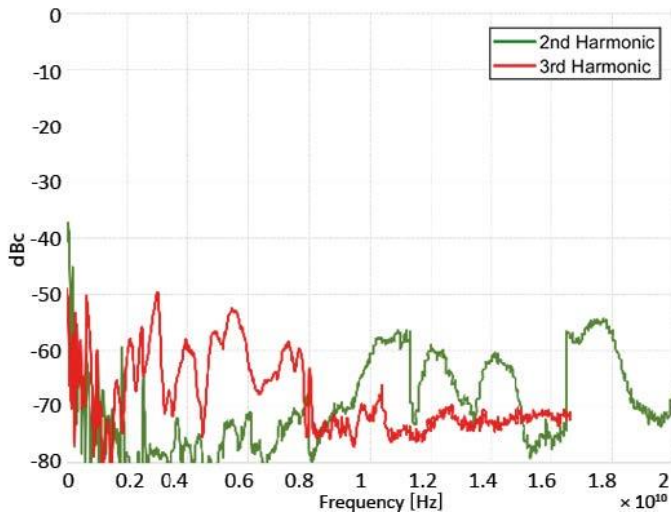

Figure 4: Non-Harmonic Spurs (12 GHz)

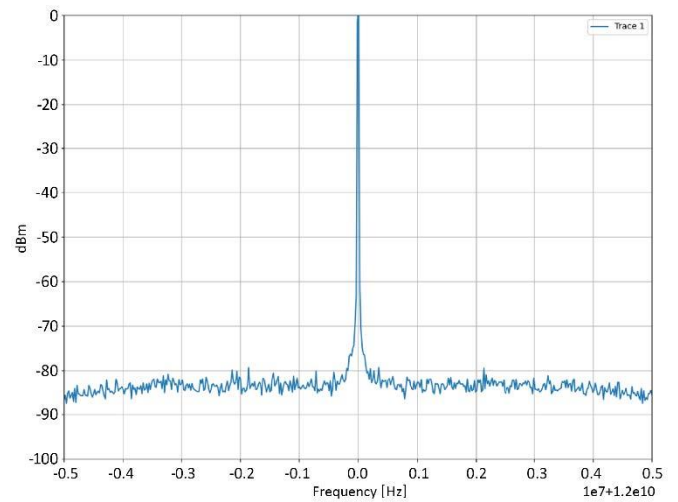

Figure 5: Non-Harmonics performance at frequencies non-fractional to the reference, 10 001 MHz

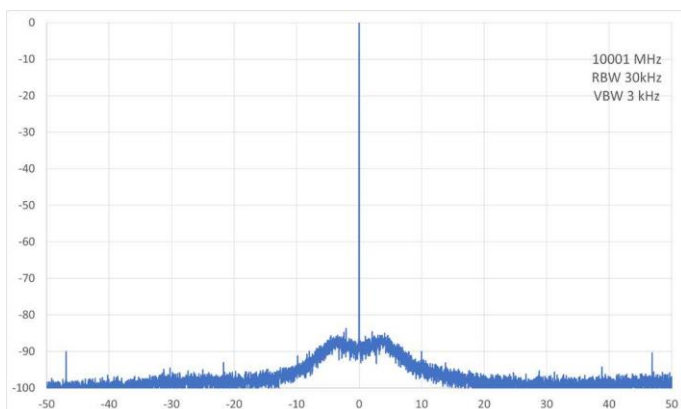
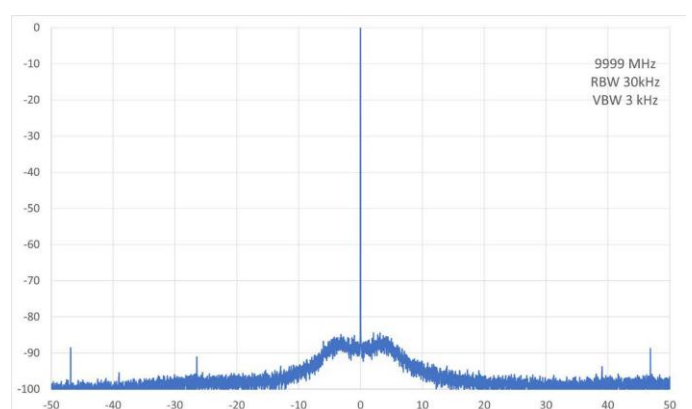

Figure 6: Non-Harmonics performance at frequencies non-fractional to the reference, 9999 MHz



Phase Coherence

PARAMETER	MIN	TYPICAL	MAX	NOTE
Relative Phase Stability			Tba	See plot
Between channels			Tba	
Between synchronized modules			Tba	
Phase-Coherent Switching				
Phase mismatch at outputs				
Channel to Channel Performance				
Isolation				
300 kHz to 54 GHz	80 dB	> 90 dB		

Figure 7: Channel-to-Channel Isolation (tba)

Figure 8: Relative Channel to channel phase stability – measured at tbd GHz, 10 dBm output in temperature-controlled environment over 10 hours (tba)

Level Performance

PARAMETER	MIN	TYPICAL	MAX	NOTE
Output Power Level				
9 kHz to 1 MHz	-20 dBm		+7 dBm	
1 MHz to 10 MHz	-20 dBm		+12 dBm	
10 MHz to 200 MHz	-20 dBm		+17 dBm	
200 MHz to 22 GHz	-20 dBm		+19 dBm	
22 GHz to 42 GHz	-20 dBm		+20 dBm	
42 GHz to 50 GHz	-20 dBm		+15 dBm	
Output Power Level				Option PE2
9 kHz to 1 MHz	-120 dBm		+7 dBm	
1 MHz to 10 MHz	-120 dBm		+12 dBm	
10 MHz to 200 MHz	-120 dBm		+16 dBm	
200 MHz to 22 GHz	-120 dBm		+16 dBm	
22 GHz to 42 GHz	-120 dBm		+16 dBm	
42 GHz to 50 GHz	-120 dBm		+12 dBm	
Power Resolution		0.01 dB		
Reverse Power Protection				
DC Voltage			±10 V	
RF Power			26 dBm	
Output Impedance		50 Ohms		
VSWR		1.3	1.5	< 15 GHz
		1.6	1.8	15 to 35 GHz
		1.9	2.2	> 35 GHz

Figure 9: Maxpower 100 MHz to 54 GHz (standard)

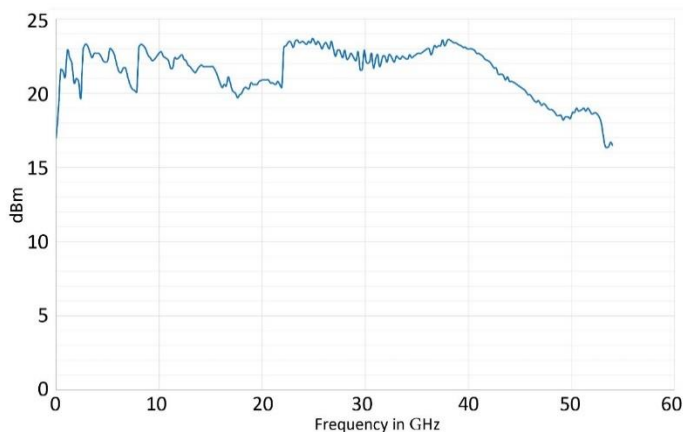
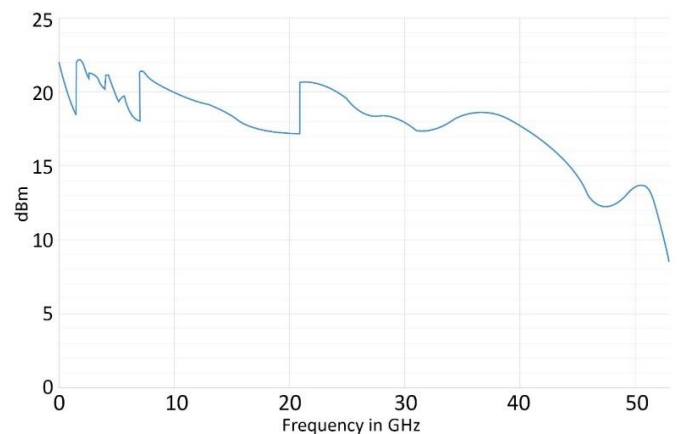

Figure 10: Maxpower 100 MHz to 54 GHz (option PE2)



Power Level Uncertainty

(): Typical Value

Frequency Range	-110 to -50 dBm Option PE2	-50 to -15 dBm Option PE2	-15 to +15 dBm	+15 dBm to Max Power
300 kHz to 6 GHz	2.0 dB	1.2 dB	0.8 dB (0.3 dB)	1.2 dB
6 to 12 GHz	2.0 dB	1.3 dB	0.9 dB (0.3 dB)	1.3 dB
12 to 20 GHz	2.0 dB	1.8 dB	1.0 dB (0.3 dB)	2.0 dB
20 to 26 GHz	2.3 dB	2.0 dB	1.2 dB (0.4 dB)	2.3 dB
26 to 54 GHz	2.5 dB	2.0 dB	1.3 dB (0.5 dB)	2.5 dB

Figure 11: Level accuracy over frequency (870A-10)

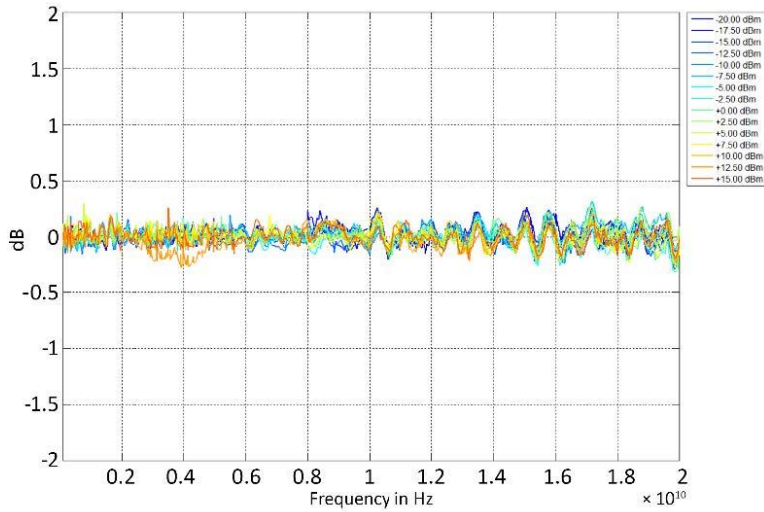

Figure 12: Level accuracy at low frequency (tba)

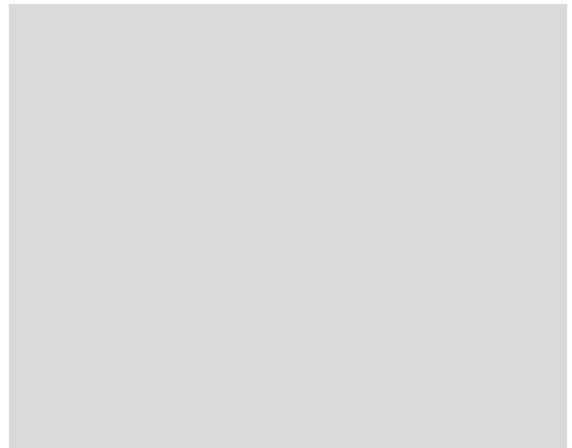
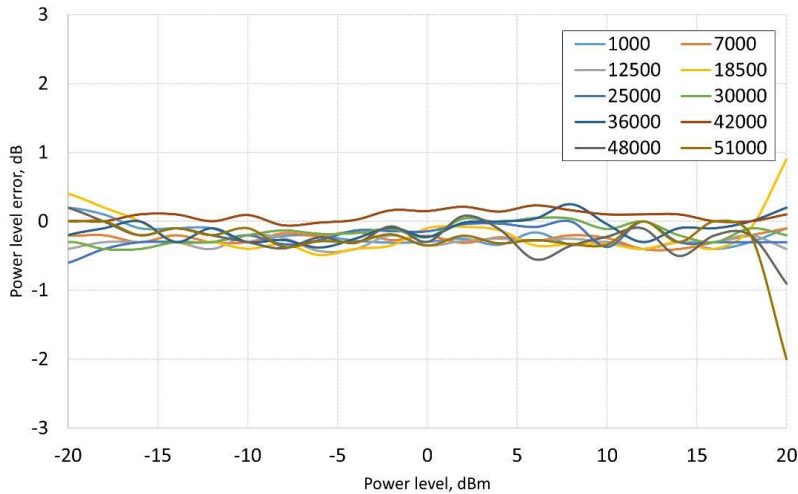

Figure 13: Power Linearity at different frequencies



Relative Power Error (0.1 dB step)

(): Typical value

Frequency Range	-110 to -50 dBm Option PE2	-50 to -15 dBm Option PE2	-15 to +15 dBm	+15 dBm to Max Power
300 kHz to 20 GHz	(< 0.1 dB)	0.5 dB (< 0.1 dB)	0.5 dB (< 0.1 dB)	(< 0.1 dB)
20 GHz to 26 GHz	(< 0.1 dB)	(< 0.1 dB)	(< 0.1 dB)	(< 0.1 dB)
26 GHz to 54 GHz	(< 0.1 dB)	(< 0.1 dB)	(< 0.1 dB)	(< 0.1 dB)

Figure 14: Absolute Power error at 54 GHz – Option PE2 (tba)

Figure 15: Relative Power error in 0.1 dB step at 54 GHz – Option PE2 (tba)

Modulation Capabilities

PARAMETER	MIN	TYPICAL	MAX	NOTE
Pulse Modulation				
Modulation Source		Internal/ External		
External input amplitude	TTL			
Pulse rise/fall time		3 ns	5 ns	
On/off ratio (power >=+10 dBm)		100 dB	80 dB	
Pulse overshoot			10%	
Pulse delay		20 ns		
Pulse polarity		Normal, inverse		Selectable
Internal pulse generator				
Repetition frequency (PRF)	0.1 Hz		50 MHz	= 1/T
Duty cycle	1 % to 99 % in 1% steps			Within specified minimum pulse width
Pulse pattern modulation & staggered PRF				Using internal pattern generator
Pulse width	100 ns 10 ns		20 s	f < 125 MHz f >= 125 MHz
Programmable pattern length	2		65536	
Duty cycle	0.05%		99.95%	
Pulse width resolution		5 ns		
Pulse period (T) accuracy		0.00005xT+ 3 ns		
Pulse width accuracy		0.00005xT+ 5 ns		
Pulse jitter		2 ns	5 ns	
Polarity		selectable		

Figure 16: Polarity Pulse On / Off ratio at +10 dBm output power and 20 ns pulse

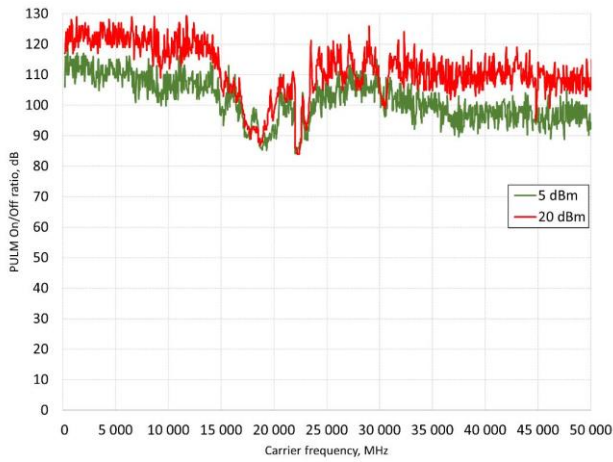

Figure 17: 10 GHz pulse modulation 30 ns

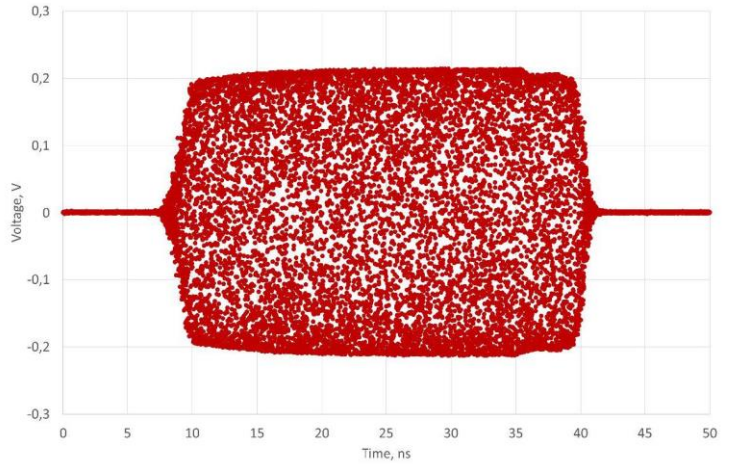
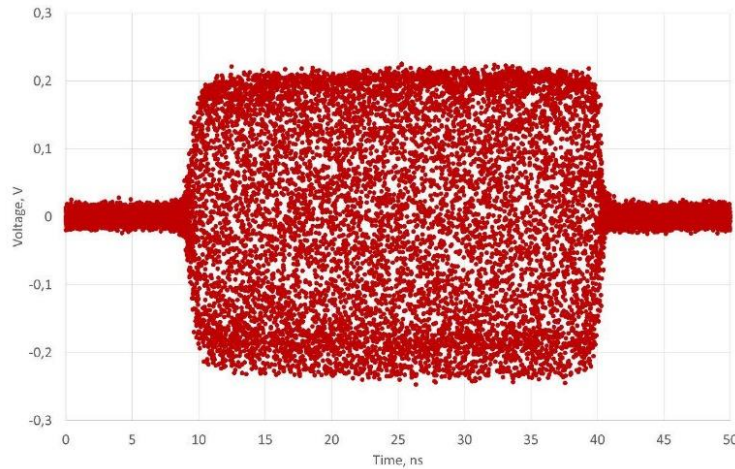

Figure 18: 50 GHz pulse modulation 30 ns



Amplitude Modulation		Tbd		Option MOD
Modulation Source		Internal		
Modulation Depth	0%		Tbd	
Deviation Accuracy		2%	Tbd	1 kHz rate, 30% depth
Deviation Resolution		1%		
Distortion (THD)			Tbd	1 kHz rate, 30% depth
Modulation rate	0.1 Hz		Tbd	
Modulation Waveforms	Sine			
Frequency Modulation		Tbd		Option MOD
Modulation source		Internal		
Maximum Frequency deviation (peak)		$N \cdot 50 \text{ MHz}$		
Deviation accuracy		0.50%	2%	
Distortion (THD)		< 1%		1 kHz rate, 10 kHz deviation
Modulation rate	0.1 Hz		30 kHz	
Modulation waveforms	Sine			
Phase Modulation		Tbd		Option MOD
Modulation Source		Internal		
Phase deviation (peak)	0		$100 \cdot N \cdot \text{rad}$	
Deviation accuracy		0.50%	2%	
Modulation rate	0.1 Hz		30 kHz	
Modulation waveforms	Sine			

Distortion (THD)	< 1%	1 kHz rate & N x rad deviation		
------------------	------	--------------------------------------	--	--

Sweeping Capability

PARAMETER	MIN	TYPICAL	MAX	NOTE
Sweep Parameters	Frequency, power, phase, list			
Sweep type	Linear, logarithmic, random			
Step time ($t_{step}=t_{dwell} + t_{off}$)	500 μ s 15 μ s		19998 s	Option FS
Dwell time (t_{dwell})	0 μ s		9999 s	
Off time (t_{off})	0 μ s		9999 s	
Time resolution		5 ns		
Timing delay (T_{de})		50 ns		
Transient time (T_{inv})			15 μ s	
Timing accuracy per point		5 ns		
Number of points	2		10000	

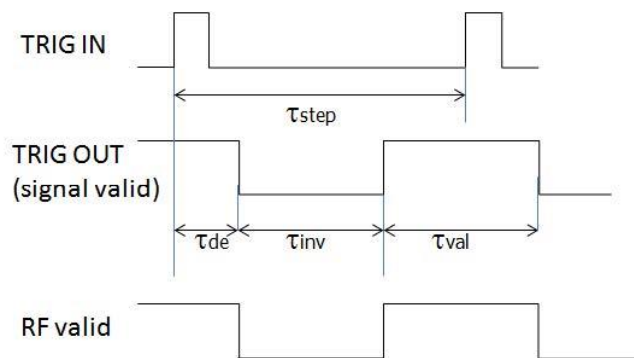

Trigger (TRIG IN)

PARAMETER	MIN	TYPICAL	MAX	NOTE
Trigger Types	Continuous Single (point) Gated Gated direction			
Trigger Source	External Bus (LAN, USB)			
Trigger Modes	Continuous free run Trigger and run Reset and run			
Trigger latency		5 ns		
Trigger Uncertainty		10 ns		
External trigger delay	50 ns		40 s	Settable
External delay resolution		5 ns		
Trigger Modulo	1		255	Execute only on Nth trigger event
Trigger Polarity		Rising Falling		
External trigger input threshold	0.85 V	0.9 V	0.95 V	TTL compatible
External trigger input voltage range	-0.5 V		+5.5 V	TTL compatible
External trigger input hysteresis		60 mV		



Multi-Purpose Output (FUNC OUT)

PARAMETER	MIN	TYPICAL	MAX	NOTE
VIDEO OUTPUT (of internal pulse modulator)				
Output		CMOS		
Period	30 ns		50 s	
Pulse width	15 ns		50 s	
RF delay		10 ns		
TRIGGER OUT Synchronization mode for multiple sources				
Modes	Trigger on sweep start Trigger on each point Signal valid			

CONNECTORS

Front panel (19" 2U)



- RF outputs:
 - 870A-12/20: SMA female
 - 870A-40: K female
 - 870A-50: 1.85/2.4 mm female
- External pulse modulation inputs: BNC female

Rear Panel (19" 2U)



- Unit-to-unit synchronization signal input (SYNC IN): SMA female
- Unit-to-unit synchronization signal output (SYNC OUT): SMA female
- Channel 1, 2, 3, 4 PULM input: BNC female
- Fast control port (FCP): 36-pin mini-D female 3M MDR 102 series
- High Stability Reference input (CLK IN, 6 GHz): SMA female
- High Stability Reference output (CLK OUT, 6 GHz): SMA female
- Trigger input (TRIG IN): BNC female
- Trigger output (TRIG OUT): BNC female
- Reference input (REF IN): BNC female
- Reference output (REF OUT): BNC female
- GPIB: IEEE-488.2, 1987 with listen and talk (optional)
- LAN connection: RJ-45
- USB 2.0 device
- Card slot (SD)
- FUSE (3.15 A)
- 100-240V AC power plug
- Power switch
- Ground reference screw (earth) M4

High Isolation Casing 19" U (rack mount kit included)



Front panel (Bench top)

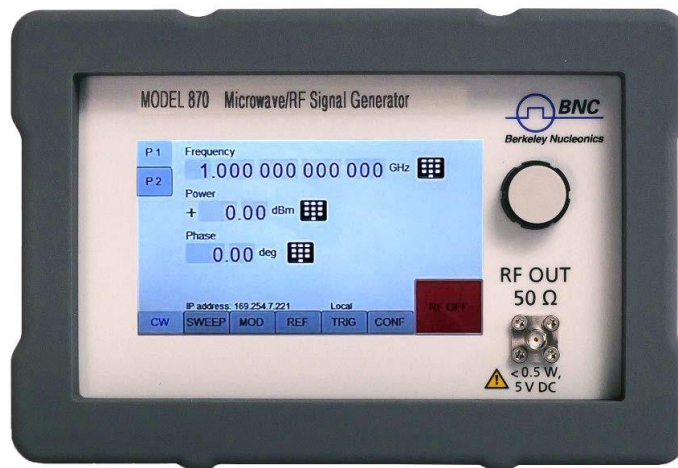

Rear panel (Bench top)



MECHANICAL SPECIFICATIONS

Desktop enclosure: Dimensions & Weight

Including connectors	W x L x H = 9.1 x 15.5 x 3.8 in [232 x 393 x 96.75 mm], ≤22 lbs [10 kg]
----------------------	---

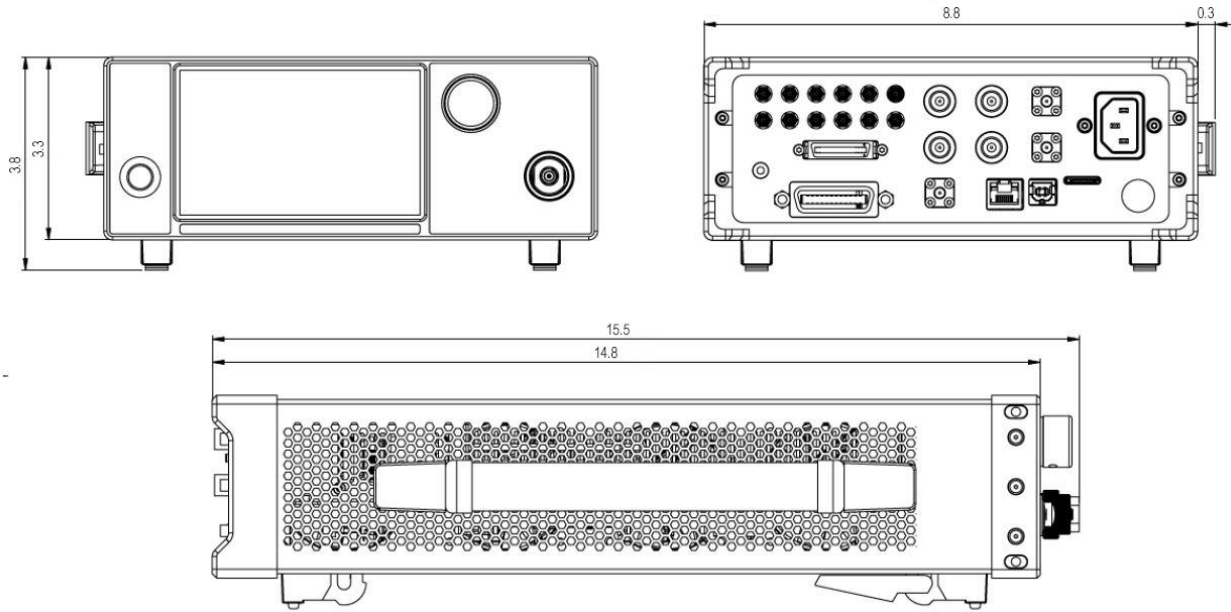

19" 2U: Dimensions & Weight

Including connectors	W x L x H = 17.5 x 23.4 x 3.5 in [444 x 594 x 88 mm], 39.7 lbs [18 kg]
----------------------	--

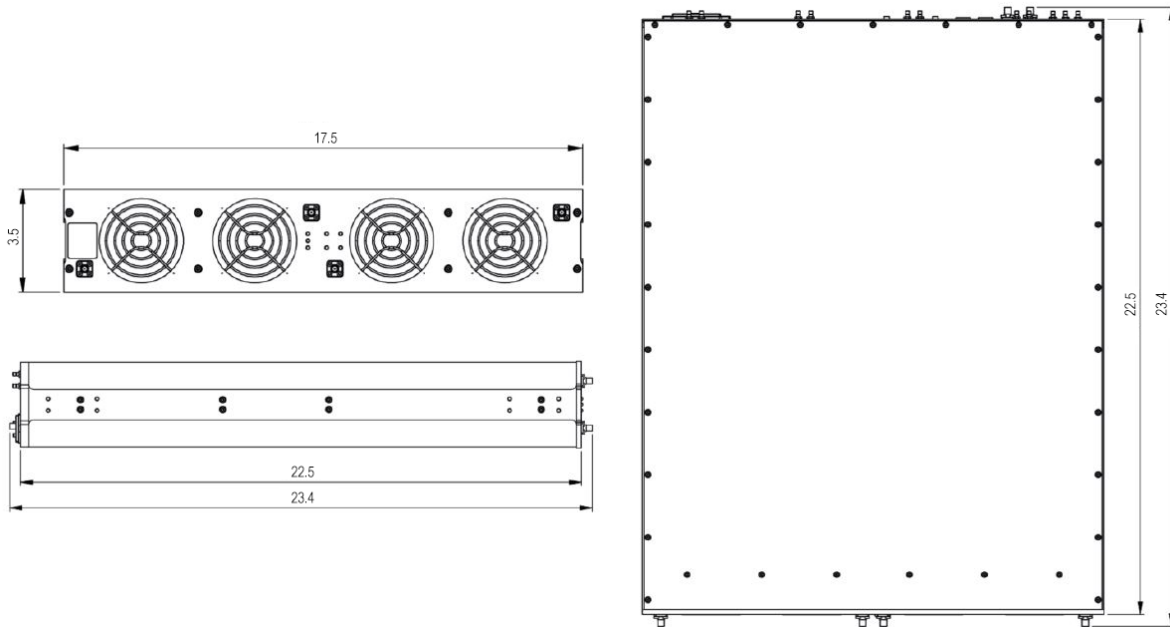

ORDERING INFORMATION

Host Model No.	Product	Description
870A	870A-12	High Performance Signal Generator up to 12.75 GHz
870A	870A-20	High Performance Signal Generator up to 20 GHz
870A	870A-40	High Performance Signal Generator up to 40 GHz
870A	870A-50	High Performance Signal Generator up to 54 GHz
870A-XX	870A-12-1	1 channel Signal Generator, up to 12.75 GHz, 19" 2HU rack-mount module
870A-XX	870A-12-2	2 channel Signal Generator, up to 12.75 GHz, 19" 2HU rack-mount module
870A-XX	870A-12-3	3 channel Signal Generator, up to 12.75 GHz, 19" 2HU rack-mount module
870A-XX	870A-12-4	4 channel Signal Generator, up to 12.75 GHz, 19" 2HU rack-mount module
870A-XX	870A-20-1	1 channel Signal Generator, up to 20 GHz, 19" 2HU rack-mount module
870A-XX	870A-20-2	2 channel Signal Generator, up to 20 GHz, 19" 2HU rack-mount module
870A-XX	870A-20-3	3 channel Signal Generator, up to 20 GHz, 19" 2HU rack-mount module
870A-XX	870A-20-4	4 channel Signal Generator, up to 20 GHz, 19" 2HU rack-mount module
870A-XX	870A-40-1	1 channel Signal Generator, up to 40 GHz, 19" 2HU rack-mount module
870A-XX	870A-40-2	2 channel Signal Generator, up to 40 GHz, 19" 2HU rack-mount module
870A-XX	870A-40-3	3 channel Signal Generator, up to 40 GHz, 19" 2HU rack-mount module
870A-XX	870A-40-4	4 channel Signal Generator, up to 40 GHz, 19" 2HU rack-mount module
870A-XX	870A-50-1	1 channel Signal Generator, up to 54 GHz, 19" 2HU rack-mount module
870A-XX	870A-50-2	2 channel Signal Generator, up to 54 GHz, 19" 2HU rack-mount module
870A-XX	870A-50-3	3 channel Signal Generator, up to 54 GHz, 19" 2HU rack-mount module
870A-XX	870A-50-4	4 channel Signal Generator, up to 54 GHz, 19" 2HU rack-mount module
870A-XX	Option FS	Ultra-fast switching speed
870A-XX	Option 9K	Frequency range extension to 9 kHz
870A-XX	Option LN	Enhanced close in phase noise and frequency stability
870A-XX	Option LN+	Option LN with improved long term frequency stability
870A-XX	Option MOD	Analog modulations added
870A-XX	Option PE2-20/40	Mechanical step attenuator down to -120dBm
870A-XX	Option PE2-50	Mechanical step attenuator down to -110dBm
870A-XX	Option PHS	Phase coherent switching
870A-XX	Option VREF	Flexible external reference frequency support in range 1 to 250 MHz
870A-XX	Option FLASH	MicroSD card slot for removable SD memory
870A-XX	Option GPIB	GPIB interface

GENERAL CHARACTERISTICS

Remote programming interfaces:

- 1 Gbit Ethernet interface
- USB 2.0 device
- GPIB (IEEE-488.2, 1987) with listen and talk (Option GPIB)

Power requirements: 100 – 240 VAC, 50 or 60 Hz, 200W maximum (80W + 30W per channel)

Environmental: levels similar to MIL-PRF-28800F Class 3 & 4



Safety / EMC comply with applicable Safety and EMC regulations and directives.

Weight: \leq 2.2 lbs (14.0 kg) net

Dimensions: 19" 2U HI enclosure
3.5 in H x 17.3 in W x 19.7 in L
(88 mm H x 440 mm W x 500 mm L)

DOCUMENT HISTORY

Version	Date	Author	Notes
V09	2023-06-25	Jk, mh	Preliminary specs, target specs, options Added preliminary plots, adapted specs based on design Updates
V091	2023-07-10	Ee	Updated phase noise plot
V100	2023-11-20	Jk	Plots added
V101	2023-12-13	Ap	Updated phase noise specs, non-harmonic performance Added pulse modulation and non-harmonics plots Added max. power plots
V102	2024-01-22	Ap, ee, ag	Updated photos and options; updated connectors
V103	2024-02-22	Ap, ag, ee, at	Updated harmonics, plots and panel photos; added new plot (pulse modulation performance)
V104	2024-03-15	AT	Added mechanical specifications

Berkeley Nucleonics Corporation

2955 Kerner Blvd.
San Rafael, CA 94901

Phone: 415-453-9955
Email: info@berkeleynucleonics.com

berkeleynucleonics.com
berkeleynucleonics.com/downloads

